

Power Units For Truck With Liftgate

General Description

Product: Power Units For Tailgate Lift

Reservoir Capacity: Steel 3.17Gal

Motor: 24V DC 2.2KW

Flow: 1.65 to 2.11 GPM

Valve: Cartridge valve

System Pressure: 1740/2320PSI

Oil Port:G1/4,G3/8,A/B

Manufacturer Warranty:1 year

Limited Warranty

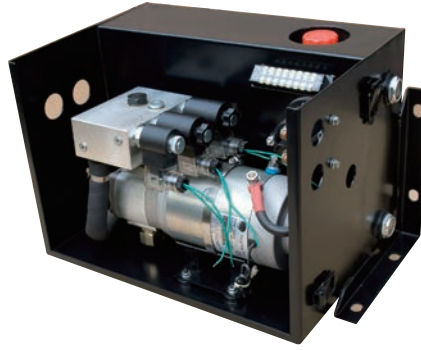

Hydraulic Circuit Diagram

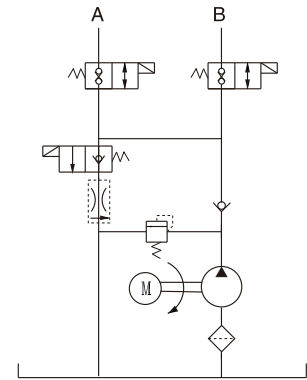

With a closed structure, this power unit is used to control the opening/closing and lifting/lowering of tailgates of trucks. The pressure compensated by the flow control valve is to be regulated the opening and lowering speed automatically.

Outline Dimension

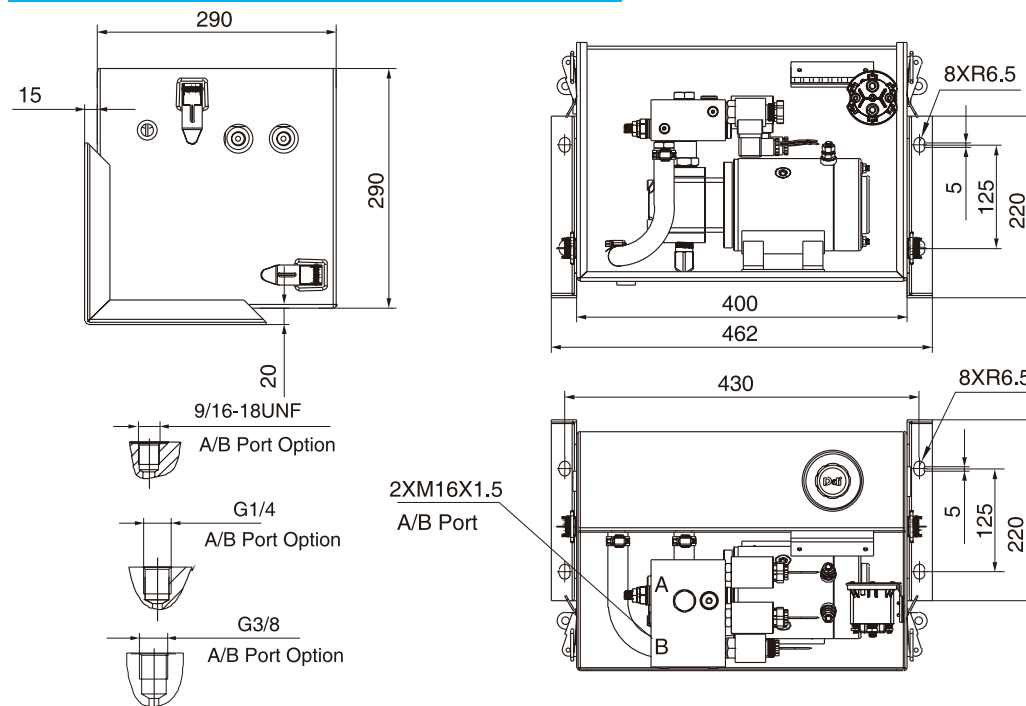

Model Specifications

Model	Motor Volt	Motor Power	Nominal Speed	Displacement	System Pressure	Tank Capacity
HPP-30E2.512D2404H	24VDC	2.2KW	2500RPM	2.5mL/r	16MPa	12L
HPP-30D3.212D2404H	24VDC	2.2KW	2500RPM	3.2mL/r	12MPa	12L

Special Notes

- 1)Due to various types of hydraulic system failure occur more than 80% of the problems are caused by hydraulic oil, so the correct use of hydraulic oil to ensure the system's reliability is very important.The oil viscosity should be 22-46mm²/s in accordance with ISO3448 viscosity classification.The hydraulic oil should be filtered by a 10-30um filter before put into use.N46 hydraulic oil is recommended.
- 2)Clean all the hydraulic parts concerned before mounting mini hydraulic power pack.Check the oil level in the tank after the initial running of small hydraulic power unit.
- 3)Oil changing is required after the initial 100 operation hours, afterwards once every 3000 hours.We are at your disposal to offer you the power unites with your favorite power,flow,pressure as well as the tank capacity.
- 4)The electric hydraulic pump should be horizontal installation.
- 5)The electric hydraulic pump is of s3 duty, i.e., non-continuous operation,30 seconds on and 270 seconds off.
- 6)To achieve thermal equilibrium of the electric motor, we have to assure that the ratio between interval time and operation time of mini hydraulic power pack is 1:9.