

Scissor Table Power Packs

General Description

Product: Hydraulic Power Units For Lift Table

Reservoir Capacity: Steel or Plastic 1.58 to 3.17Gal

Motor: 380V AC 2.2KW

Flow: 1.18 to 1.99 GPM

Valve: Cartridge valve

System Pressure: 1740 to 2900PSI

Oil Port: G1/4 or M14x1.5 P1/P2

Manufacturer Warranty: 1 year Limited

Warranty

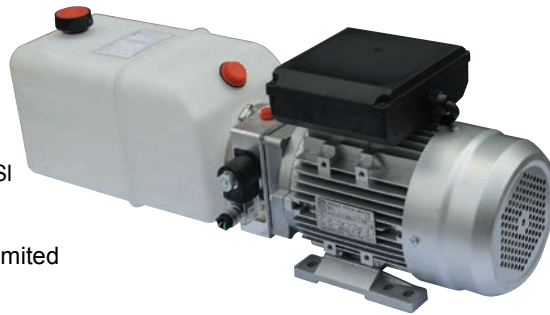

Hydraulic Circuit Diagram

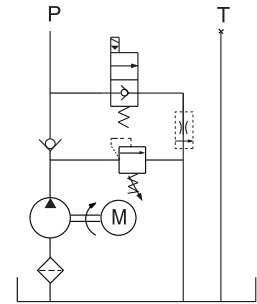

Scissor table power unit has been widely used in the industry of logistic devices such as Electric lift table, Scissor Table and Pallet Lift Table. The lowering movement is controlled by cartridge solenoid valve and its speed is controlled by the adjustable throttle valve, which can protect the Scissor table effectively. The needle release valve is used for lowering movement when the power fails to use. The manual override function is available on request.

60HZ motors with CSA or UL certification are available upon request.

Outline Dimension

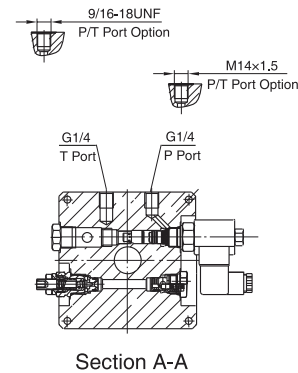
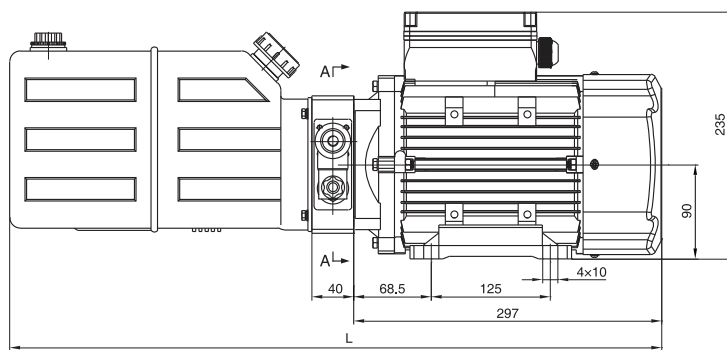

Model Specifications

Model	Motor Volt	Motor Power	Rated Speed	Displacement	System Pressure	Tank Capacity	L(mm)
HPP-2F1.66A2203H	220VAC	1.5KW	2800RPM	1.6mL/r	20MPa	6L	629
HPP-2E2.16A2203H				2.1mL/r	16MPa	6L	629
HPP-2D2.58A2203H				2.5mL/r	12MPa	8L	699
HPP-2F2.18A3804H	380VAC	2.2KW		2.1mL/r	20MPa	8L	699
HPP-2E2.510A3804H				2.5mL/r	16MPa	10L	769
HPP-2E2.712A3804H				2.7mL/r	15MPa	12L	869

Special Notes

1)Due to various types of hydraulic system failure occur more than 80% of the problems are caused by hydraulic oil, so the correct use of hydraulic oil to ensure the system's reliability is very important. The oil viscosity should be 22-46mm²/s in accordance with ISO3448 viscosity classification. The hydraulic oil should be filtered by a 10-30um filter before put into use. N46 hydraulic oil is recommended.

2)Clean all the hydraulic parts concerned before mounting mini hydraulic power pack. Check the oil level in the tank after the initial running of small hydraulic power unit.

3)Oil changing is required after the initial 100 operation hours, afterwards once every 3000 hours. We are at your disposal to offer you the power unites with your favorite power, flow, pressure as well as the tank capacity.

4)The electric hydraulic pump should be horizontal installation.

5)The electric hydraulic pump is of s3 duty, i.e., 30 seconds on and 270 seconds off.

6)To achieve thermal equilibrium of the electric motor, we have to assure that the ratio between interval time and operation time of mini hydraulic power pack is 1:9.