

# Power Units For Scissor Lift

## General Description

Product: Power Units For Scissor Lift

Reservoir Capacity: Steel 2.11 to 6.6Gal

Motor: 220V AC 2.2KW

Flow: 1.0 to 3.11 GPM

Valve: Cartridge valve

System Pressure: 1450 to 3190PSI

Oil Port: G1/4 or M14x1.5 A/B

Manufacturer Warranty: 1 year Limited

Warranty



## Hydraulic Circuit Diagram

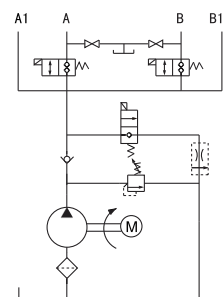

This power pack is equipped with the zero leakage double-check solenoid valves, and fulfils the complete separation of the two independent circuits which are respective for the main platform and subordinate platform of the double scissors lift. By increasing the number of the solenoid valves is easy to get more independent circuits, which are used to control the corresponding hydraulic cylinders.

Cartridge solenoid valve with manual override function is available on request.

AC motors with CSA or UL certification are available upon request.

## Outline Dimension

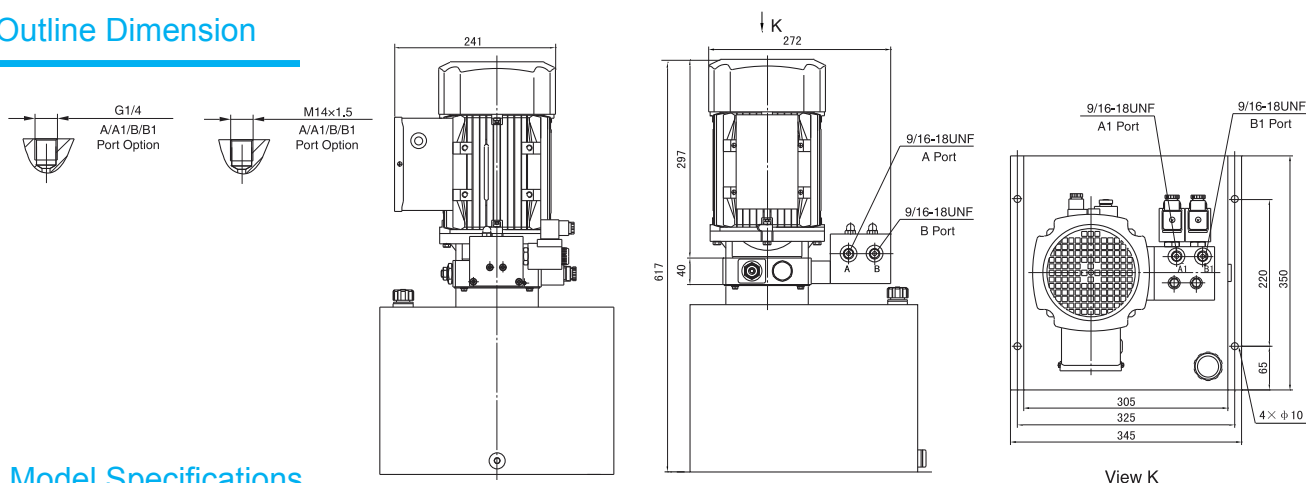

## Model Specifications

Model	Motor Volt	Motor Power	Rated Speed	Displacement	System Pressure	Tank Capacity	
HPP-30F2.78A2203V	220VAC	1.5KW	1400RPM	2.7mL/r	22MPa	8L	
HPP-30F3.212A2203V				3.2mL/r	20MPa	12L	
HPP-30F2.514A2204V		2.2KW	2800RPM	2.5mL/r	18MPa	16L	
HPP-30E3.216A2204V				3.2mL/r	15MPa		
HPP-30D4.216A2204V	380VAC	3KW	2800RPM	4.2mL/r	10MPa	20L	
HPP-30F2.720A3805V				2.7mL/r	20MPa		
HPP-30F3.222A3805V				3.2mL/r	18MPa		22L
HPP-30E3.725A3805V				3.7mL/r	16MPa		25L

## Special Notes

1)Due to various types of hydraulic system failure occur more than 80% of the problems are caused by hydraulic oil, so the correct use of hydraulic oil to ensure the system's reliability is very important.The oil viscosity should be 22-46mm<sup>2</sup>/s in accordance with ISO3448 viscosity classification.The hydraulic oil should be filtered by a 10-30um filter before put into use.N46 hydraulic oil is recommended.

2)Clean all the hydraulic parts concerned before mounting mini hydraulic power pack.Check the oil level in the tank after the initial running of small hydraulic power unit.

3)Oil changing is required after the initial 100 operation hours, afterwards once every 3000 hours.We are at your disposal to offer you the power unites with your favorite power,flow,pressure as well as the tank capacity.

4)The electric hydraulic pump should be vertical installation.

5)The electric hydraulic pump is of s3 duty, which can only work intermittently and repeatedly,i.e., 1 minute on and 9 minutes off.

6)To achieve thermal equilibrium of the electric motor, we have to assure that the ratio between interval time and operation time of mini hydraulic power pack is 1:9.