

Power Packs For Loading Dock Lift

General Description

Product: Power Unit For Dock Leveler

Reservoir Capacity: Steel or Plastic 0.92 to 1.58Gal

Motor: 380V 0.75KW

Flow: 0.80 to 1.03 GPM

Valve: Cartridge valve

System Pressure: 2030/2320PSI

Oil Port:G1/4 or M14x1.5 P1/P2

Manufacturer Warranty:1 year Limited
Warranty



Hydraulic Circuit Diagram

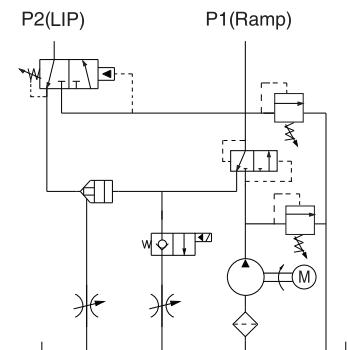

When the power pack system with a cartridge solenoid valve is normally open, it makes the ramp and lip float with the carriage during loading and unloading. The power unit also offers an emergency stop function while falling.

60HZ motors with CSA or UL certification are available upon request.

Outline Dimension

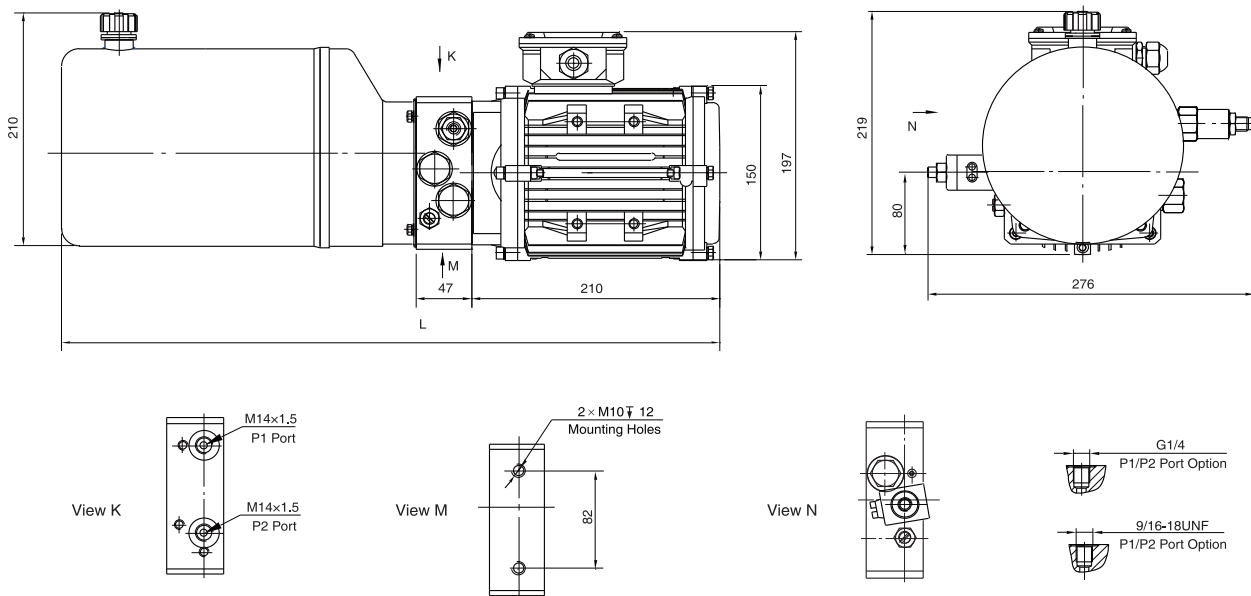

Model Specifications

Model	Motor Volt	Motor Power	Displacement	System Pressure	Tank Capacity	L(mm)
HPP-82E2.13.5A3801H	380VAC	0.75KW	2.1mL/r	16MPa	3.5L	457
HPP-82E2.76A3801H			2.7mL/r	14MPa	6L	557

Special Notes

- 1)Due to various types of hydraulic system failure occur more than 80% of the problems are caused by hydraulic oil, so the correct use of hydraulic oil to ensure the system's reliability is very important.The oil viscosity should be 22-46mm²/s in accordance with ISO3448 viscosity classification.The hydraulic oil should be filtered by a 10-30um filter before put into use.N46 hydraulic oil is recommended.
- 2)Clean all the hydraulic parts concerned before mounting mini hydraulic power pack.Check the oil level in the tank after the initial running of small hydraulic power unit.
- 3)Oil changing is required after the initial 100 operation hours, afterwards once every 3000 hours.We are at your disposal to offer you the power unites with your favorite power,flow,pressure as well as the tank capacity.
- 4)The electric hydraulic pump is of s3 duty, which can only work intermittently and repeatedly,i.e., 1 minute on and 9 minutes off.
- 5)To achieve thermal equilibrium of the electric motor, we have to assure that the ratio between interval time and operation time of mini hydraulic power pack is 1:9.