

Pallet Lift Table Power Packs

General Description

Product: Hydraulic Power Units For Lift Table

Reservoir Capacity: Steel 2.11Gal

Motor: 220V AC 1.5KW

Flow: 0.77 GPM

Valve: Cartridge valve

System Pressure: 2900PSI

Oil Port:G1/4 or M14x1.5

Manufacturer Warranty:1 year Limited
Warranty

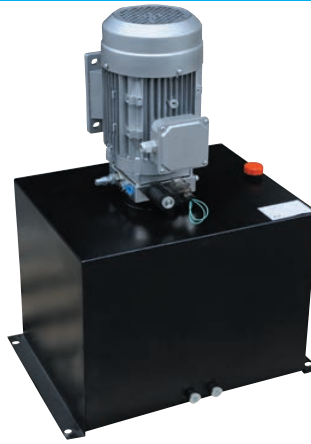

Hydraulic Circuit Diagram

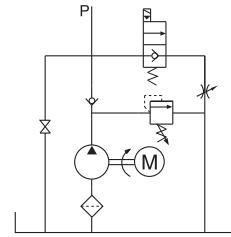

Pallet Lift table power unit has been widely used in the industry of logistic devices such as Electric lift table, Scissor Table and Pallet Lift Table. The lowering movement is controlled by cartridge solenoid valve or cartridge manual valve and the speed is controlled by the adjustable throttle valve, so that it can protect the Pallet lift table effectively. The manual override function is available on request.

60HZ motors with CSA or UL certification are available upon request.

Outline Dimension

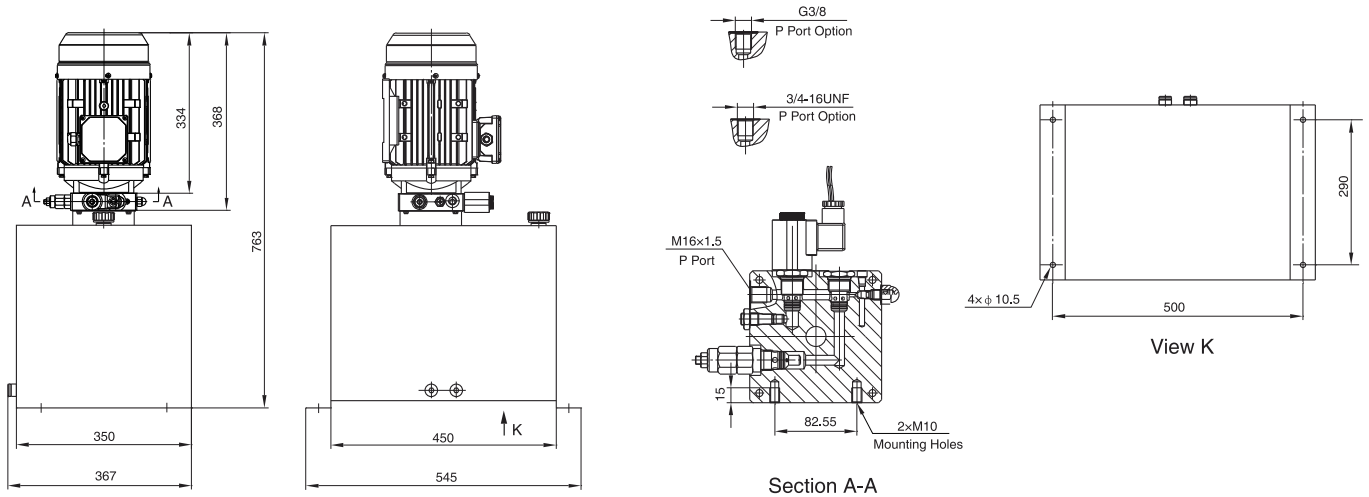

Model Specifications

Model	Motor Volt	Motor Power	Rated Speed	Displacement	System Pressure	Tank Capacity
HPP-56F2.18A2203H	220VAC	1.5KW	1400RPM	2.1mL/r	20MPa	8L

Special Notes

1)Due to various types of hydraulic system failure occur more than 80% of the problems are caused by hydraulic oil, so the correct use of hydraulic oil to ensure the system's reliability is very important.The oil viscosity should be 22-46mm²/s in accordance with ISO3448 viscosity classification.The hydraulic oil should be filtered by a 10-30um filter before put into use.N46 hydraulic oil is recommended.

2)Clean all the hydraulic parts concerned before mounting mini hydraulic power pack.Check the oil level in the tank after the initial running of small hydraulic power unit.

3)Oil changing is required after the initial 100 operation hours, afterwards once every 3000 hours.We are at your disposal to offer you the power unites with your favorite power,flow,pressure as well as the tank capacity.

4)The electric hydraulic pump should be horizontal installation.

5)The electric hydraulic pump is of s3 duty, which can only work intermittently and repeatedly, ie., 1 minute on and 9 minutes off.

6)To achieve thermal equilibrium of the electric motor, we have to assure that the ratio between interval time and operation time of mini hydraulic power pack is 1:9.