

Hydraulic Dump Trailer Dump

General Description

Product: Hydraulic Pump for Dump Trailer

Reservoir Capacity: Steel or Plastic 1.32/1.58Gal

Motor: 24V DC 2KW

Flow: 1.05 to 1.65 GPM

Valve: Cartridge valve

System Pressure: 2900PSI

Oil Port: G1/4 or M14x1.5

Manufacturer Warranty: 1 year Limited

Warranty

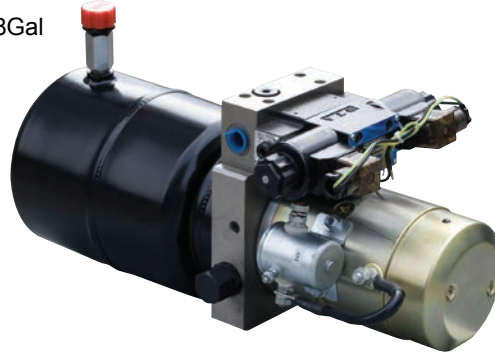

Hydraulic Circuit Diagram

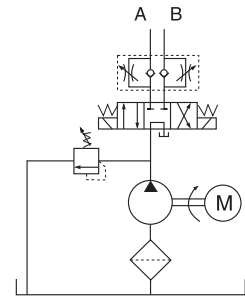

This power unit is designed solely for dump trailer, by motor power up, power down. The second relief valve provides an extra protection for the machine when lowering. To push the start button on the motor can lift the trailer. The lowering movement is activated by the solenoid cartridge valve, while the lowering speed is controlled by cartridge flow valve in the return circuit. The power unit is also applied in the industry of logistic devices such as hydraulic dump trailer, trailer dump, Dumping trailers and utility trailers etc.

Outline Dimension

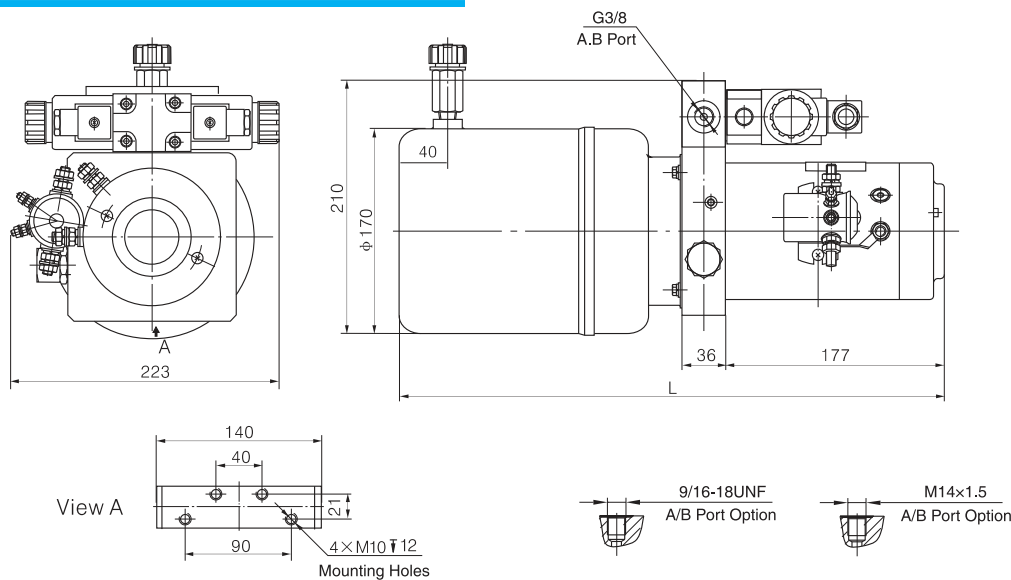

Model Specifications

Model	Motor Volt	Motor Power	Displacement	System Pressure	Tank Capacity	L(mm)
HPP-8F1.63.5D1203H	12VAC	1.5KW	1.6mL/r	18MPa	3.5L	448
HPP-8F2.55D2404H	24VAC	2KW	2.5mL/r	18MPa	5L	463

Special Notes

- 1)Due to various types of hydraulic system failure occur more than 80% of the problems are caused by hydraulic oil, so the correct use of hydraulic oil to ensure the system's reliability is very important.The oil viscosity should be 22-46mm²/s in accordance with ISO3448 viscosity classification.The hydraulic oil should be filtered by a 10-30um filter before put into use.N46 hydraulic oil is recommended.
- 2)Clean all the hydraulic parts concerned before mounting mini hydraulic power pack.Check the oil level in the tank after the initial running of small hydraulic power unit.
- 3)Oil changing is required after the initial 100 operation hours, afterwards once every 3000 hours.We are at your disposal to offer you the power unites with your favorite power,flow,pressure as well as the tank capacity.
- 4)The electric hydraulic pump should be horizontal installation.
- 5)The electric hydraulic pump is of s3 duty, i.e., non-continuous operation,30 seconds on and 270 seconds off.
- 6)To achieve thermal equilibrium of the electric motor, we have to assure that the ratio between interval time and operation time of mini hydraulic power pack is 1:9.